

IJ-TUP100-01 Take-Up Unit 100Kg Operation Manual

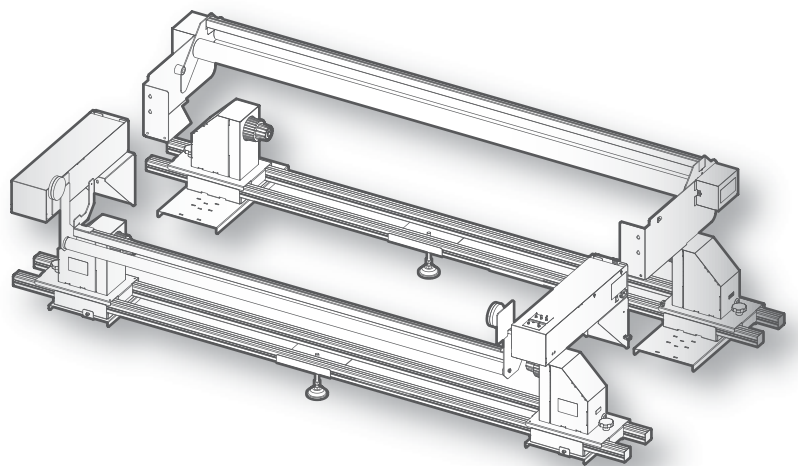

INTRODUCTION	2
CONNECTING THE CABLES	5
POWERING ON / OFF	7
ATTACH THE WEIGHT FOR TAKE-UP UNIT	8
LOADING THE MEDIA	10
BASIC OPERATION.....	27
MAINTENANCE.....	30
MOVING OR TRANSPORTING THE PRINTER.....	32
TROUBLESHOOTING.....	34
SAFETY INSTRUCTIONS	37
SPECIFICATIONS OF THIS PRODUCT	42
OPTIONS LIST	43
REVISION HISTORY	43

-
- Unauthorized copying or duplication of the whole or part of the contents of this Guide is prohibited.
 - Every care has been taken in writing the contents of this Guide, but please contact MUTOH or the dealer you purchased the product from if you find any unclear, erroneous or otherwise unsatisfactory content in the Guide.
 - Please be aware that MUTOH will not be liable in any way for failures or accidents that result from handling or operating the printer according to any procedures other than those set forth in this Guide.
 - Company names and product names that appear in this Guide are registered trademarks of the respective companies.

Introduction

Name of each part

Take-up Unit

Take-up Unit

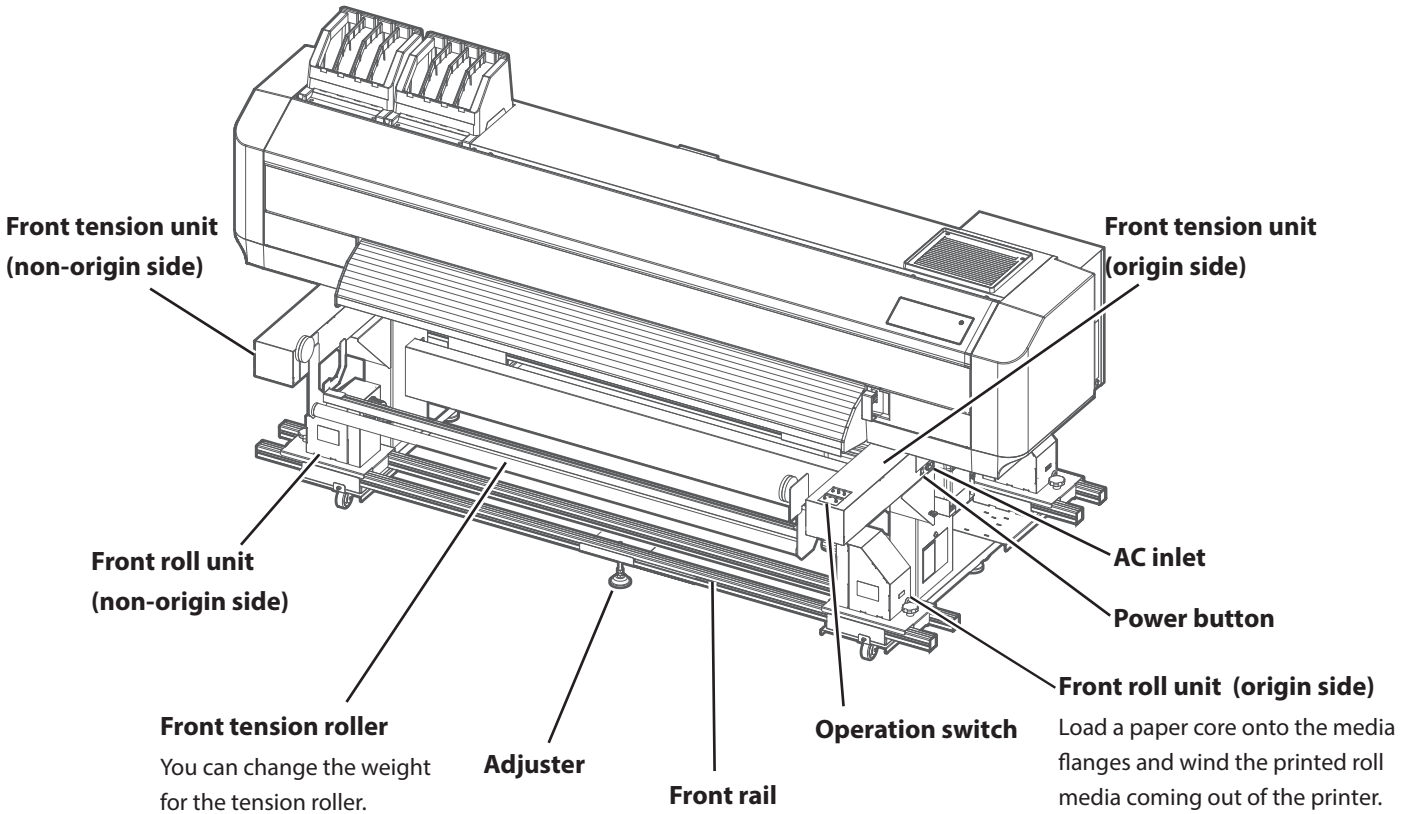

Feeding Unit

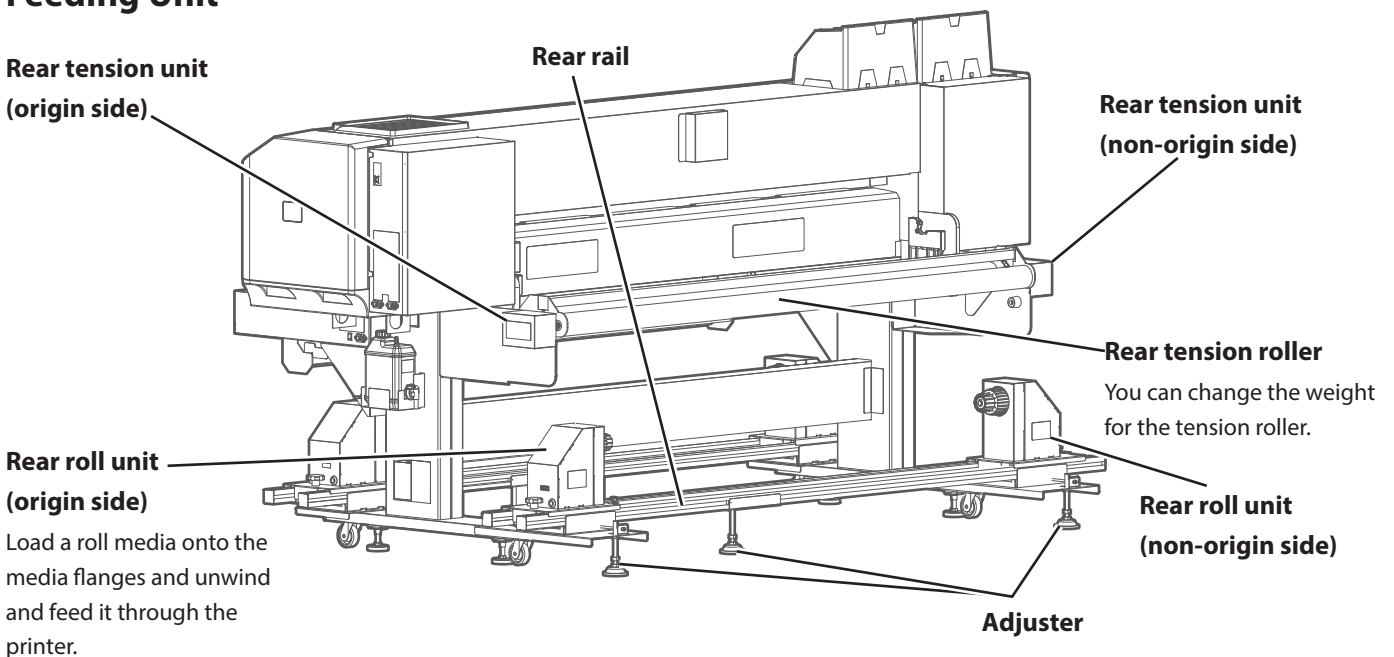

Operation switch (Take-up Unit)

Feeding Unit (rear side)

Error lamp

Lights up or blinks red to indicate an error.

① AUTO switch

Here you can configure the Feeding Unit during the printing operation.

- OUTSIDE ROLL
Use this setting for the outside roll media.
- OFF
The media is not taken up automatically.
- INSIDE ROLL
Use this setting for the inside roll media.

② INITIALIZE button

Press to move the rear tension roller to the feeding position ("INITIAL" position).

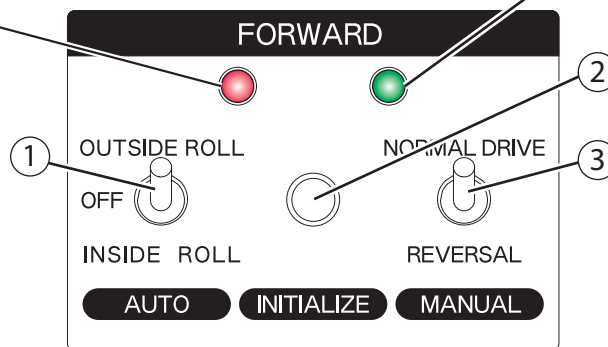

Operation lamp

Lights up green when the power is on. During the operation, it blinks.

③ MANUAL switch

By holding the switch in a slanted position, you can operate the Feeding Unit manually.

- NORMAL
Use this setting to feed the media.
- REVERSAL
Use this setting to take up the media.

<Attention>

If the media rolling method and the AUTO switch setting don't match, the operations above are not available.

Take-up Unit (front side)

Error lamp

Lights up or blinks red to indicate an error.

① AUTO switch

Sets the media rolling method. Unless the switch is set to OFF, the printer will automatically feed or take up the media when printing.

- OUTSIDE ROLL
Use this setting to wind with the printed side face out.
- OFF
The media is not taken up automatically.
- INSIDE ROLL
Use this setting to wind with the printed side face in.

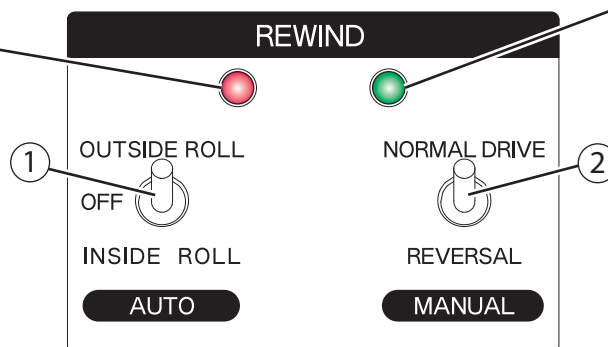

Operation lamp

Lights up green when the power is on. During the operation, it blinks.

② MANUAL switch

By holding the switch in a slanted position, you can operate the Take-up Unit manually.

- NORMAL
Use this setting to take up the media.
- REVERSAL
Use this setting to feed the media.

<Attention>

If the media rolling method and the AUTO switch setting don't match, the operations above are not available.

CAUTION

Do not stand, sit, or lean on the following parts. Applying excessive load will deform these parts, affecting print quality.

- front tension unit (origin side and non-origin side)
- front tension roller
- rear tension unit (origin side and non-origin side)
- rear tension roller
- front roll unit (origin side and non-origin side)
- front rail
- rear roll unit (origin side and non-origin side)
- rear rail

Environmental Condition

Use this Unit under the following printer environmental condition:

Environmental conditions (complies with the printer operating condition)	Operating environment	Temperature 20 to 32 °C, Humidity 40 to 60% No condensation
	Recommended Printing Environment	Temperature 22 to 30 °C, Humidity 40 to 60% No condensation
	Storage Environment	Temperature -20 to +60 °C, Humidity 40 to 80% No condensation

Required items for installing and using the product

To use the product, you will need the following items in addition to the packaged items.

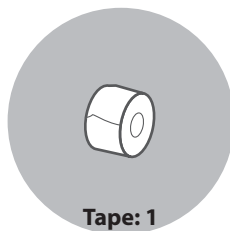
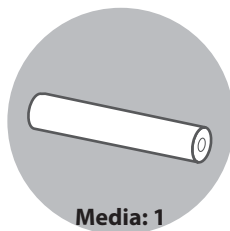
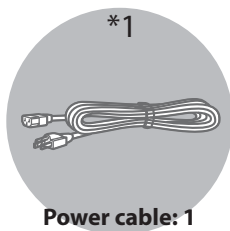

Note

- *1: Items is accessory.

WARNING

Be sure to use a power cable of the specified type.

Using any other power cable could result in electric shock or fire.

Connecting the cables

Connecting power cable

1. Before connecting the cables...

Close the front cover.

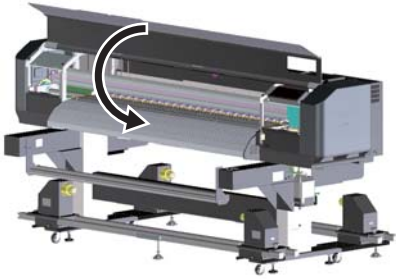

2. Connecting the power cable

[1]

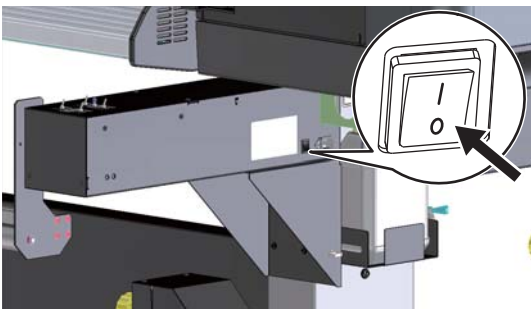

Make sure that the Take-up Unit is turned OFF.

 **Note**

- The power switch to the Take-up Unit is on the Front tension unit (origin side).
- When the [Power] key is set toward [I], the printer is ON. Put it back to [O] and turn it OFF.

[2]

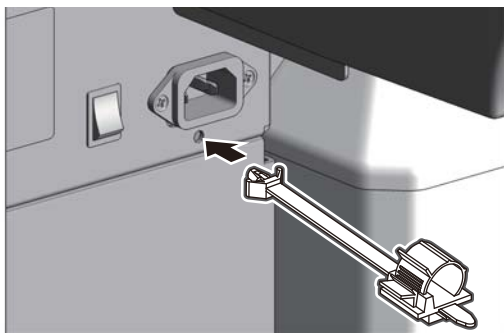

Attach the cord clamp to the front tension unit (on the origin side).

[3]

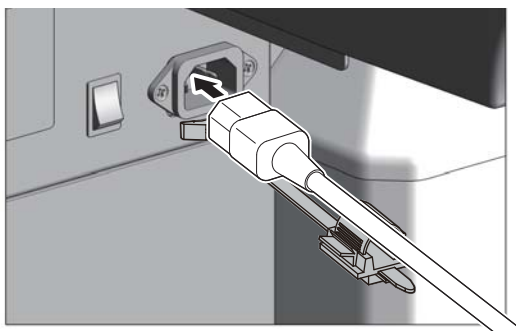

Connect the power cord of the heavy-duty take-up unit to the printer.

[4]

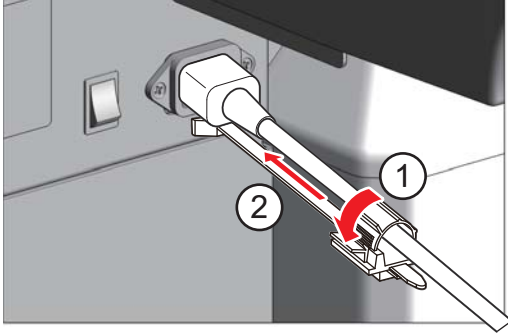

Secure the power cord to the cord clamp.

1. Pass the power cord through the clamp and clamp until it clicks into place.
2. Slide the clamp toward the inlet.



WARNING

Make sure to plug two power cords into the wall outlets with the same voltage.

Failure to do so may cause damage to the electrical circuit.

[5]

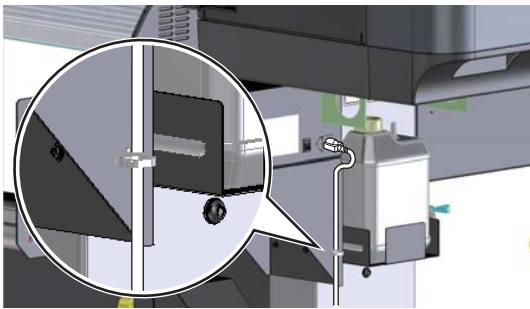

Pass the power cord through the clamp on the lower side.

[6]

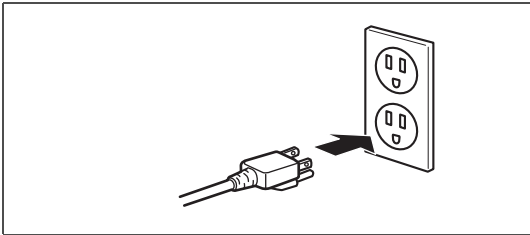

Plug the power cord into the wall outlet.



Important!

Do not use power strips.

Powering ON / OFF

Turning the power ON

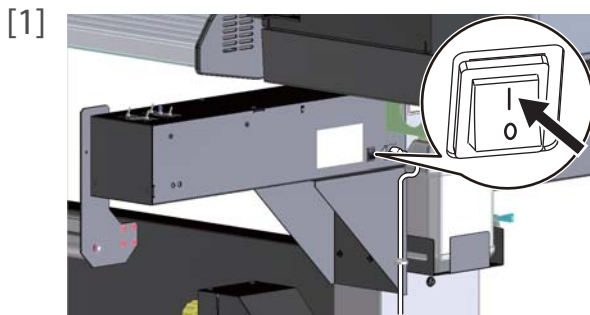

Press the power button to turn the power ON.
• The green light becomes ON.

Important!

If a roll media is loaded in the printer and take-up unit, make sure to press the INITIALIZE button to move the rear tension roller to "INITIAL" position. If it is not in "INITIAL" position, the internal sensor will not work correctly, failing to perform proper media feeding.

 [「Moving rear tension roller to "INITIAL" position」 P. 29](#)

Turning the power OFF

[1] Make sure printing is done.

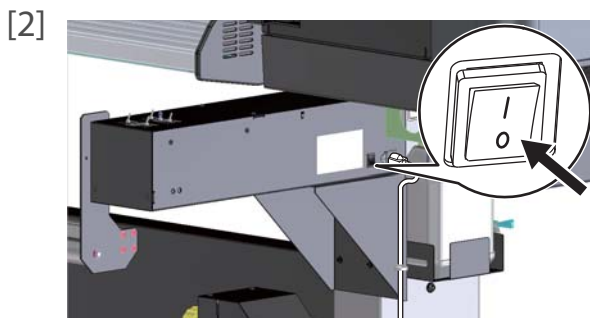

Press the power button to turn the power OFF.
• The green light becomes OFF.

Attach the Weight for Take-Up Unit

Please attach the included weight for take-up unit (hereinafter referred to as "Weight"). By attaching a weight according to the media type, the media tension can be corrected. Printing without weight may result in quality decrease.

Important!

- **Attaching weight is recommended, but this will not guarantee the print quality or feeding accuracy.**

The attachment position of weight differs depending on the media type.

☞ 「For Normal Media」 P. 8

☞ 「For Cloth Media」 P. 9

☞ 「For Transfer Paper, Tarpaulin」 P. 9

Note

- The media tension will be affected by the media thickness and stretching property. If the print quality is decreased, please try different weight attaching position for different media.
- For the available media type, please refer to the operation manual for each printer.

For Normal Media

To use a normal media (Plain Paper, Marking Film etc.), follow the procedures below to attach the weight.

[1]

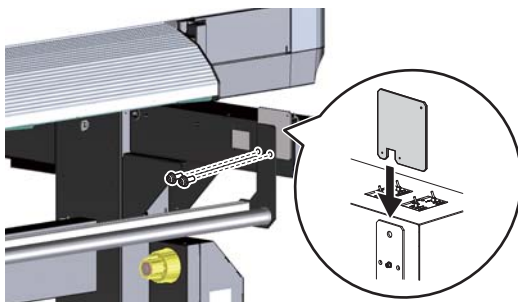

Attach the counter weight mount board to the origin side of the front tension roller with two M3×6 screws.

- Insert the counter weight mount board between the front tension roller and the front tension unit (origin side).

[2]

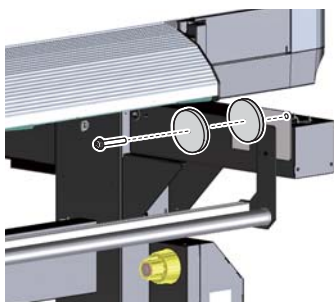

Attach the weight (2 pieces) to the counter weight mount board with a M4×30 screw.

[3]

Follow the step 1 through step 2 to attach the weight to the non-origin side as well.

For Cloth Media

To use a cloth media (ex. Banner cloth), follow the procedures below to attach the weight.

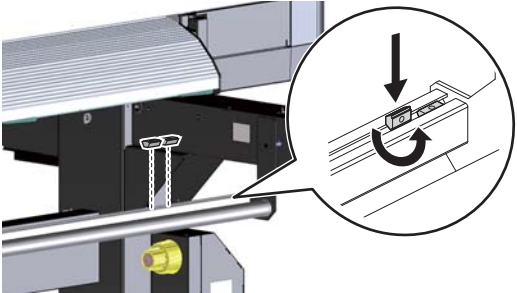
- [1] 

Attach two post-assembly insertion nuts to the balance frame on the front tension roller.

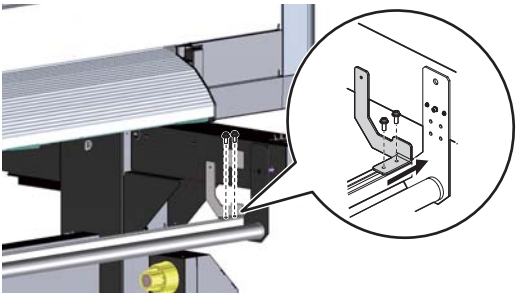
 - Insert two nuts into the groove on the balance frame.
 - Turn the nuts inside of the balance frame until its hole side is facing up.
- [2] 

Attach the weight mount board R to the origin side of the front tension roller. Insert and tighten the two M4×12 screws in the post-assembly insertion short nut.

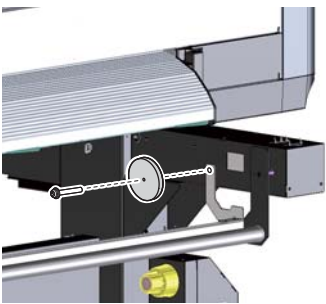
 - Press the weight mount board R against to the arm part of tension roller to fix.
- [3] 

Attach the weight (1 piece) to the weight mount board R with a M4×16 screw.
- [4] Follow the step 1 through step 3 to attach the weight and the weight mount board L to the non-origin side as well.

For Transfer Paper, Tarpaulin

To use a transfer paper or tarpaulin, follow the procedures below to attach the weight.

- [1] 

Attach the weight (1 piece) to the origin side of the rear tension roller with a M4×16 screw.
- [2] Follow the step 1 to attach the weight to the non-origin side as well.

Note

- For transfer paper or tarpaulin, the weight does not need to be attached to the front tension roller.

Loading the media

Requirements for usable media

Media that meet the requirements below can be used with this printer.

Usable sizes

Media Core Dimension	50.8 mm (2 inch), 76.2 mm (3 inch)
Maximum width	1,625 mm
Minimum width	500 mm
Outside diameter of the roll media	Less than $\Phi 250$ mm
Roll media weight	100 kg or less

Media Rolling Methods

This product allows the following media rolling methods.

Outside Roll

With this rolling method, the printed surface is on the outside.

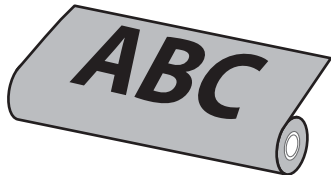

Inside Roll

With this rolling method, the printed surface is on the inside.

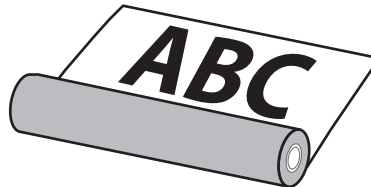

Important!

- The mounting position of the rear rail unit varies depending on the printable side of roll media.
Before loading a roll media, check that the mounting position of the feed unit is appropriate for your roll media.
- Mounting position for Outside roll

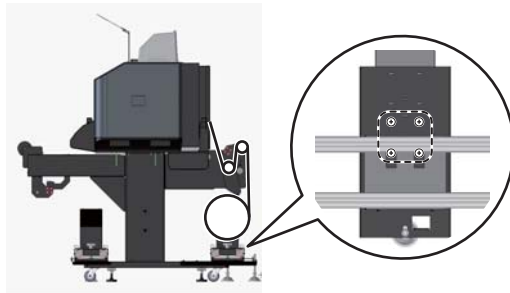

- Mounting position for Inside roll (or when using both Inside and Outside rolls)

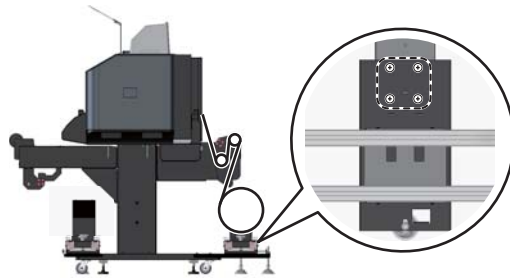

- If you want to change from Outside roll to Inside roll after installation, please contact your local MUTOH dealer to change the mounting position.
It should be performed by trained service personnel only.

Preparations of printer

[1]

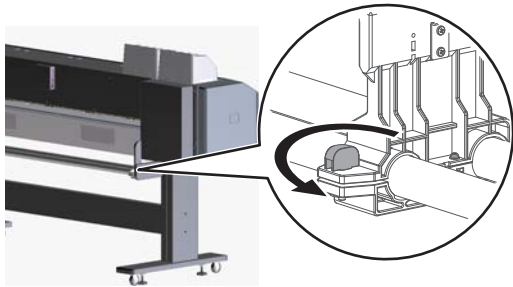

Twist the knob bolt on the both side of the media holders anticlockwise to loosen.

[2]

Slide both left and right media holders towards the outside of the slider.

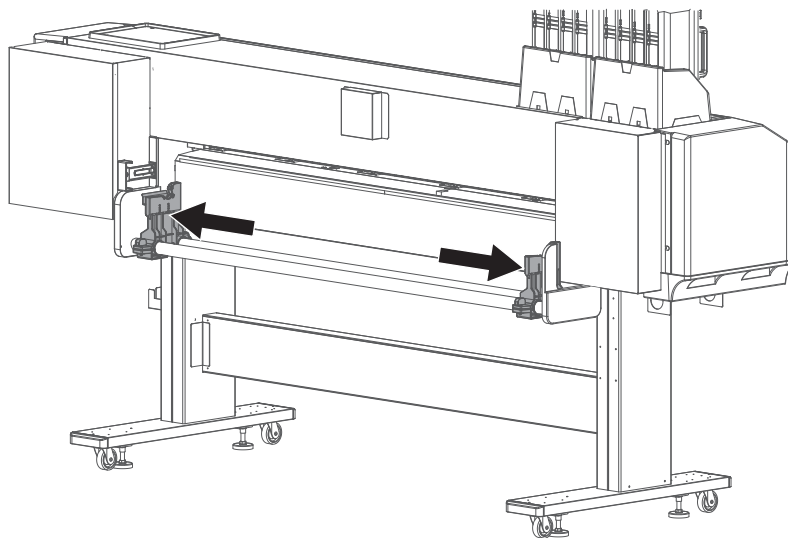

[3]

Tighten the knob bolts on both media holders.

Set the media to the Feed Unit

CAUTION

If the media is heavy, please work with more than 2 people.

[1]

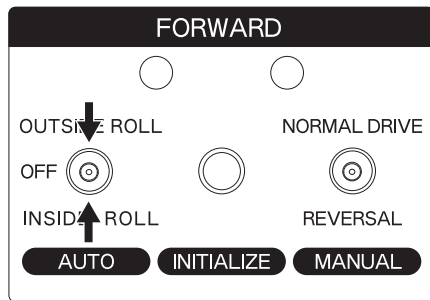

Make sure the AUTO switch for the Feed unit is OFF.

[2]

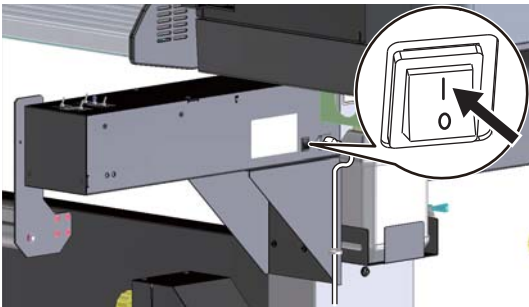

Press the power button to turn the power ON.

[3]

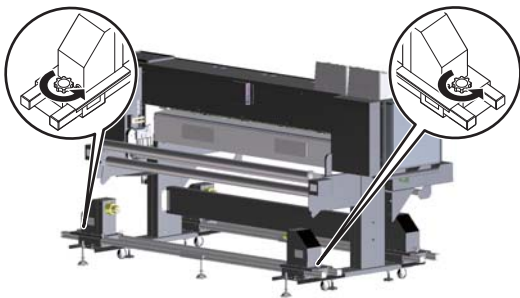

Loosen both handles on the rear roll unit.

[4]

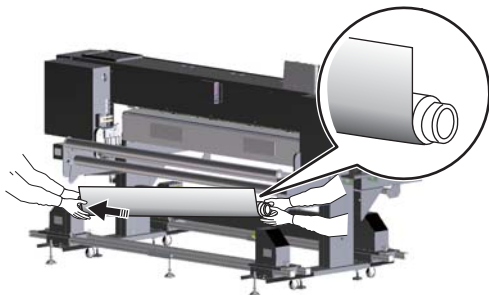

Attach the roll media to the origin side of the rear roll unit.

- Hold the roll media and insert it into the origin side of the rear roll unit to attach.
- For the outside roll media, see the left illustration.

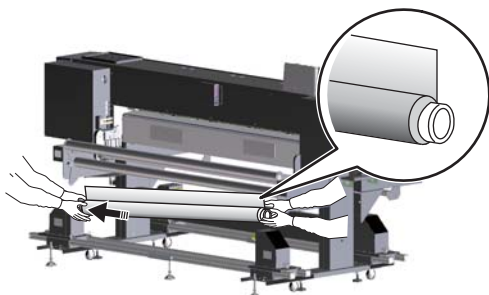

- For the inside roll media, see the left illustration.

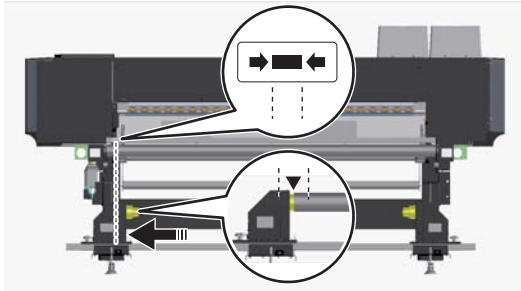

- Move the origin side of the rear roll unit to the position that the left end of the roll media (▼ in the left illustration) is aligned within the mark on the label applied to the balance frame on the rear tension roller (within the range between two dotted lines shown left).

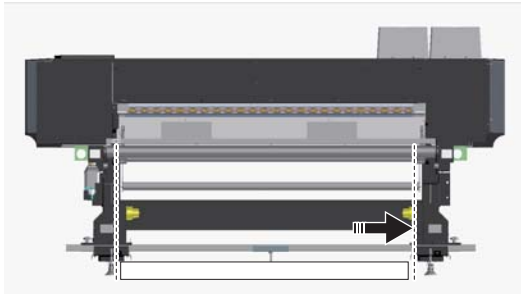

- Move the non-origin side of the rear roll unit to the appropriate position so that the roll media can be attached to the unit.

[5]

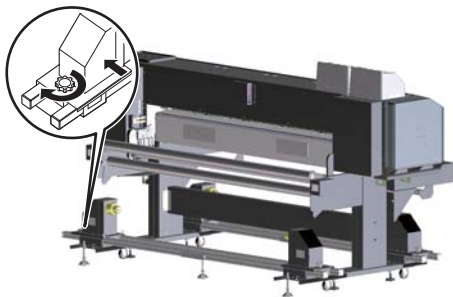

- Tighten the handle on the origin side of the rear roll unit.
- Push the rear roll unit against the printer to tighten it.

[6]

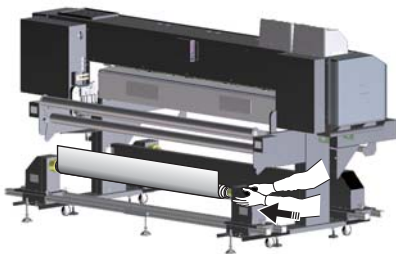

- Move the non-origin side of the rear roll unit and attach the roll media.
- Push the roll media against the origin side of the rear roll unit to attach it.

Important!

- **Make sure to firmly push it towards the flange. If it is not firmly attached, the roll media will spin out and the take-up unit will not operate properly.**

[7]

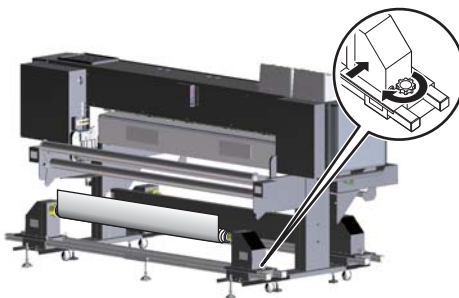

- Tighten the handle on the non-origin side of the rear roll unit.
- Push the rear roll unit against the printer to tighten it.

Put the media through the printer from the Feed Unit

[1]

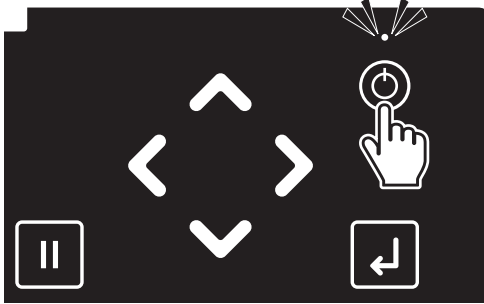

Long press the Power button.

- The printer will start mechanical initialization.
- The operation panel will display “Media End”.

Note

- The Power LED (above the Power button) lights up.

[2]

In the setup menu of the printer, check if the menu to use the take-up unit is set to On.

Operation manual for each printer

[3]

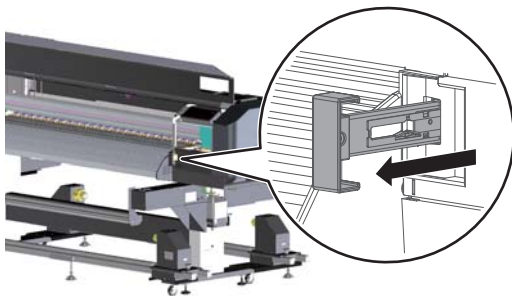

From the front side of the printer, pull the media feed lever towards you as much as possible to release the pressure rollers.

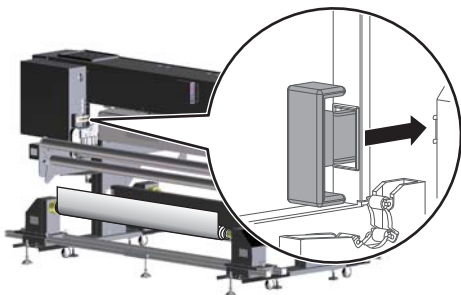

You can access to the media feed lever from the rear side of the printer.

- To release the pressure rollers, push the media feed lever.
- To lock the pressure rollers, pull it towards you.

Note

- Using this lever, the hold down pressure can be changed between High and Normal. To apply high pressure, pull the lever towards you as much as possible.

[4]

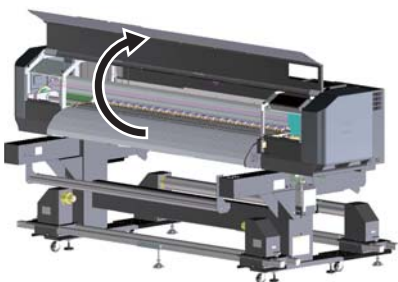

Open the front cover.

[5]

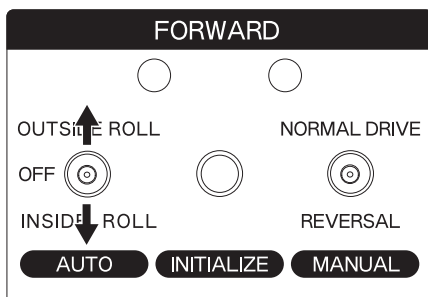

Switch the Feed Unit AUTO switch depending on the media you are setting.

- INSIDE ROLL: When setting the inside roll media.
- OUTSIDE ROLL: When setting the outside roll media.

Note

- Inside roll media: Media with the printable side on the inside.
- Outside roll media: Media with the printable side on the outside.

[6]

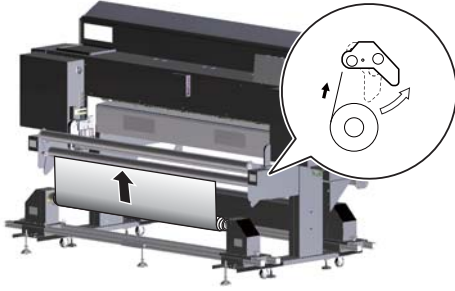

Hold the leading edge of a roll media with your one hand and push the rear tension roller as far as it will go to unwind roll media.

- Roll media is automatically unwound while you push the rear tension roller.
- To stop unwinding, release your hand from the rear tension roller.

[7]

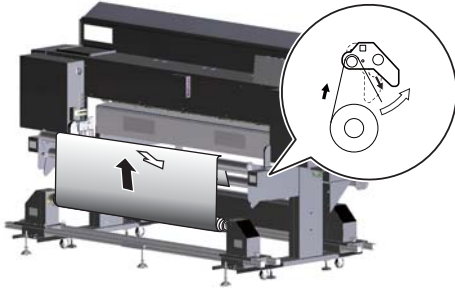

Pass the roll media through over the roller in the front, then under the roller in the back as shown.

- For the outside roll media, see the left illustration.

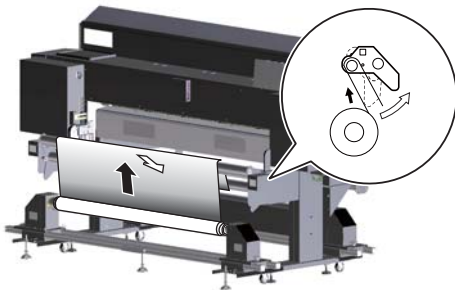

- For the inside roll media, see the left illustration.

[8]

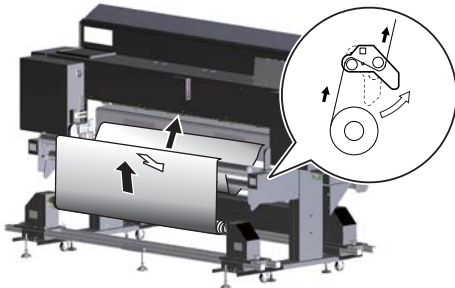

Pass it under the roller in the back, then up to pass through the rear tension roller as shown.

[9]

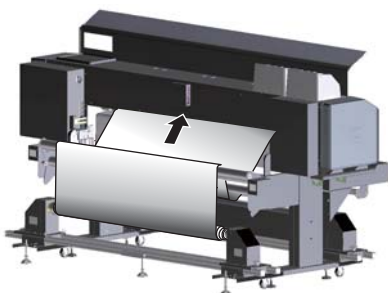

Insert the media into the media feed slot.

- Insert it until the leading edge of the roll media passes under the pressure rollers.

[10]

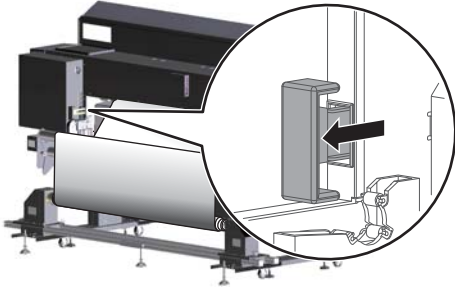

Lower the pressure rollers to temporarily hold down the roll media.

- From the rear of the printer, pull the media feed lever towards you to lower the pressure rollers.

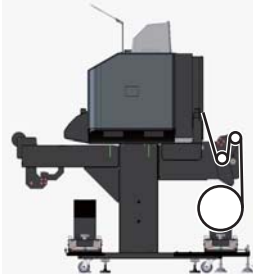

The media should be loaded to the roller as shown in the illustration when seen from the side.

- For the outside roll media

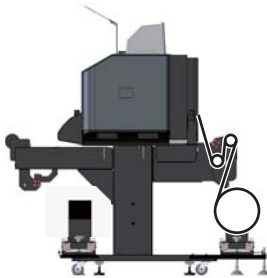

- For the inside roll media

Set the paper core to the Take-up Unit

[1]

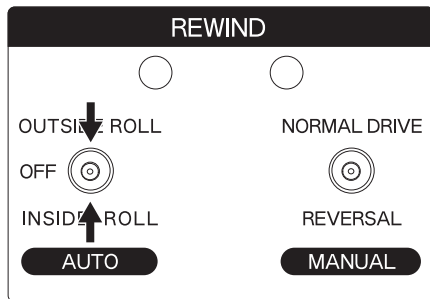

Go to the front of the printer and make sure the AUTO switch for the Take-Up Unit is OFF.

[2]

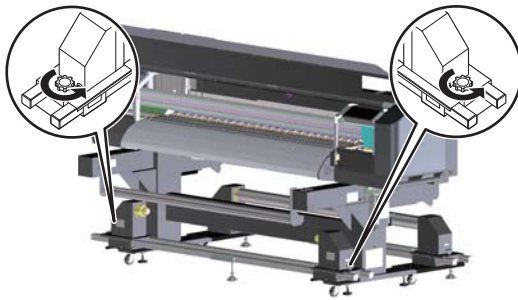

Loosen both handles on the front roll unit.

[3]



Attach a paper core to the origin side of the front roll unit.

- Hold a paper core and insert it into the origin side of the front roll unit to attach.

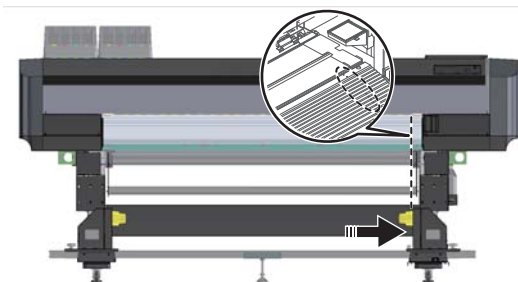

- Align the origin side of the front roll unit with the media registration guide holes on the printer (holes on the media guide).

Note

- Print quality defect may occur if the right end of the paper core is located to the right of the media registration guide holes.
- Precise alignment will be performed later in the skew adjustment on the feed unit.

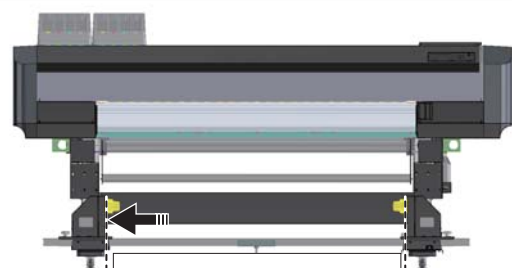

- Move the non-origin side of the front roll unit to the appropriate position so that the paper core can be attached to the unit.

[4]

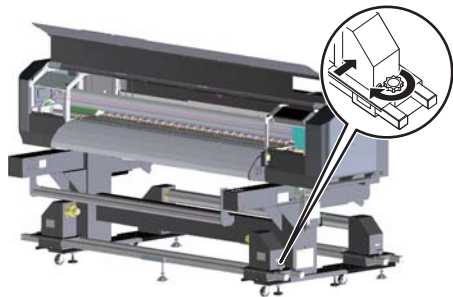

Tighten the handle on the origin side of the front roll unit.

- Push the front roll unit against the printer to tighten it.

[5]



Move the non-origin side of the front roll unit and attach the paper core.

- Push the paper core against the origin side of the front roll unit to attach it.

 **Important!**

- **Make sure to firmly push it towards the flange. If it is not firmly attached, the paper core will spin out and the take-up unit will not operate properly.**

[6]

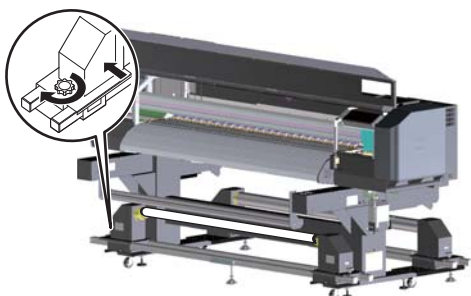

Tighten the handle on the non-origin side of the front roll unit.

- Push the front roll unit against the printer to tighten it.

Remove any warps or skew from the roll media on the Feed Unit

Before loading the roll media onto the take-up unit, follow these steps to remove any warps or skew from the roll media on the feed unit.

Important!

- **Printing without removing media warps or skew will cause print defects such as misalignment of the print position.**

[1]

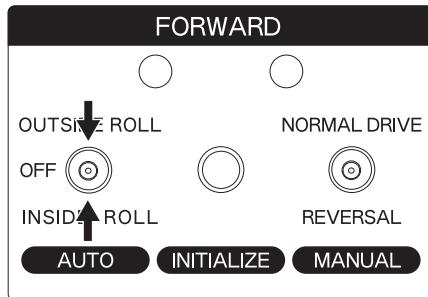

Set the AUTO switch of the Feed Unit to "OFF".

[2]

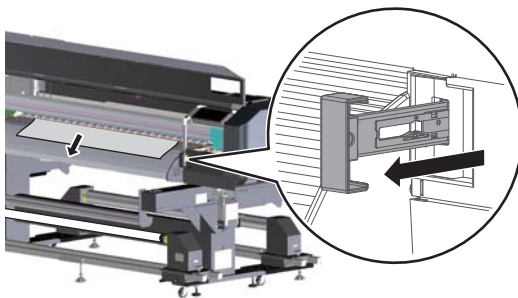

Laise the pressure rollers and pull the media from the media feed slot.

- Hold the center on the leading edge of the roll media, and pull the media feed lever towards you as much as possible to release the pressure rollers.

Note

- If you do not hold the leading edge of the roll media while pulling the lever, it will fall out of the media feed slot onto the rear of the printer.

[3]

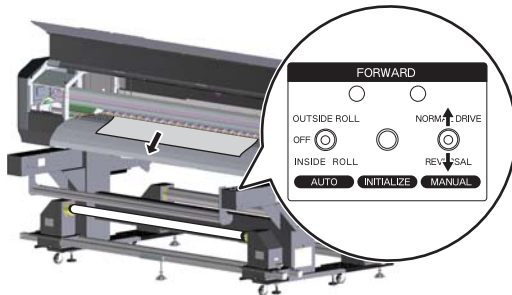

Turn the MANUAL switch on the feed unit according to the printing side of your roll media to pull the roll media out about 1 m.

- When the leading edge of the media reaches the intended position, release your hand from the switch.

When using the outside roll:

- "NORMAL DRIVE" will feed roll media forward.
- "REVERSAL" will feed roll media backward.

When using the inside roll:

- "REVERSAL" will feed roll media forward.
- "NORMAL DRIVE" will feed roll media backward.

[4]

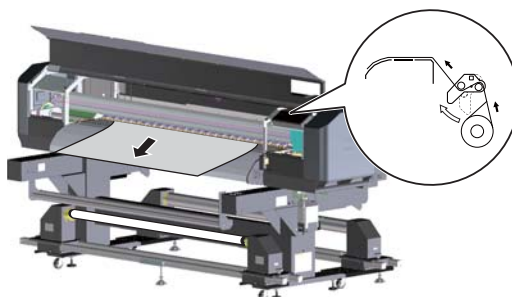

Pull the media until the rear tension roller stops.

- Pull it straight with equal force on the left and right side of the media to avoid skew.

[5]

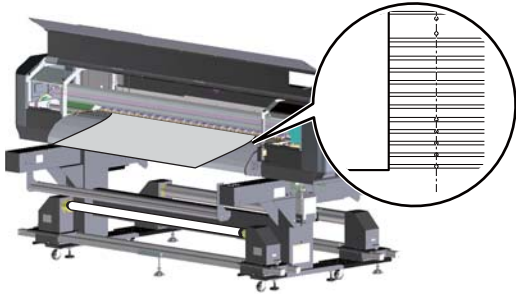

While you pull the roll media straight, check the position of the right end of the roll media.

- Make sure that the right end of the media is NOT located to the right of the media registration guide holes.

Note

- Print quality defect may occur if the right end of the adjustment paper is located to the right of the media registration guide holes.
Rewind the roll media back to the feed unit, reboot the take-up unit, and reload the roll media.

[「Powering ON / OFF」 P. 7](#)

[「Set the media to the Feed Unit」 P. 13](#)

- Check the right end position of the roll media and the paper core on the Take-up Unit.

Note

- If the right end of the roll media is located to the right of the paper core, it will affect the take-up unit operation.
Adjust the position of the front rail unit so that the right end of the paper core is located at least 2 mm to the right of the right end of the roll media.

[「Set the paper core to the Take-up Unit」 P. 18](#)

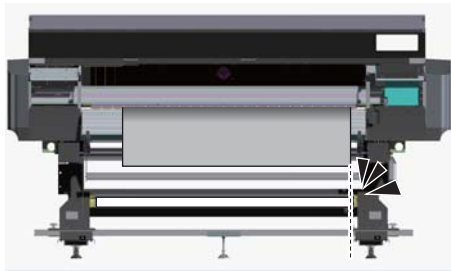

[6]

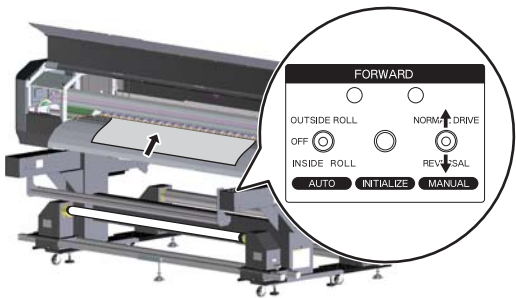

While holding the center of the roll media on the paper guide with one hand, feed the media backward to remove warps or skew.

When using the outside roll:

- Put the MANUAL switch of the Feeding Unit in the "REVERSAL" will feed roll media backward.

When using the inside roll:

- Put the MANUAL switch of the Feeding Unit in the "NORMAL DRIVE" will feed roll media backward.

Note

- Make sure to hold the roll media with your hand on the media guide (not on the platen). Do not apply excessive force to the platen.
- Rewind evenly on the left and right sides of the roll media.
- Do not release your hand from the media. It will fall out of the media feed slot onto the rear of the printer.

- Rewind the roll media until the leading edge of the media reaches the upper part of the media guide.

- Once rewound, push the media feed lever as far as it will go to lower the pressure rollers.

Note

- If the leading edge of the roll media is rewound to the platen, the printer may not be able to detect it. Use the control panel on the feed unit to adjust the position.

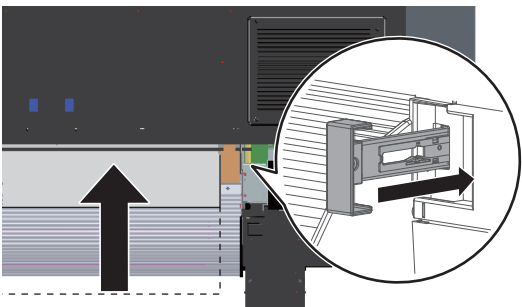

[7]

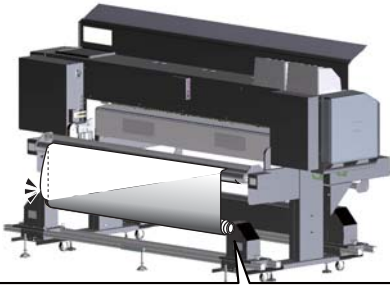

Go to the rear of the printer and check that there is no warp or skew on the roll media.

- Check if the roll media is rewound evenly on the left and right sides in the step 6. If either end of the roll media is misaligned, skew occurs.
- Check if the tension on the left and right side of the media between the feed unit and rear tension roller is equal. If it is unequal, either end of the media has warps.

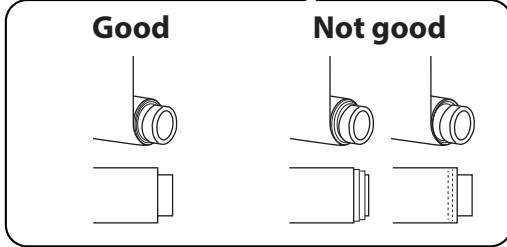

Note

- In case the media warp or skew occurs, go back to the step 1 to do it again.

[8]

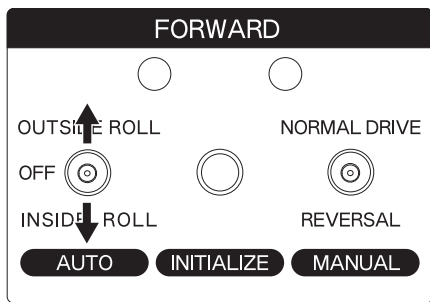

Once you have checked that the roll media does not have warps or skew, change the AUTO switch on the feed unit according to the printing side of the roll media to be loaded.

- **INSIDE ROLL:** When setting the inside roll media.
- **OUTSIDE ROLL:** When setting the outside roll media.

Note

- **Inside roll media:** Media with the printable side on the inside.
- **Outside roll media:** Media with the printable side on the outside.

[9] Move the rear tension roller to "INITIAL" position.

[「Moving rear tension roller to "INITIAL" position」 P. 29](#)

Attaching roll media to the paper core

- [1] Place the edge holders on both edges of the media.



In the default setting, the printer starts printing with 5 mm margin on the sides. DO NOT hold down the edge of the media more than 5 mm with the edge holder.

Operation manual for each printer

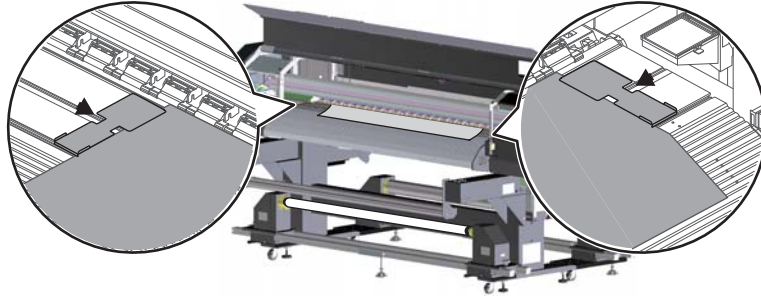

- [2]

Close the front cover.



- [3]



"User: Type** OK?" appears on the touch panel.

- Use or to choose the correct user type and tap [Enter] to start media initialization.
- End the media loading.

- [4]

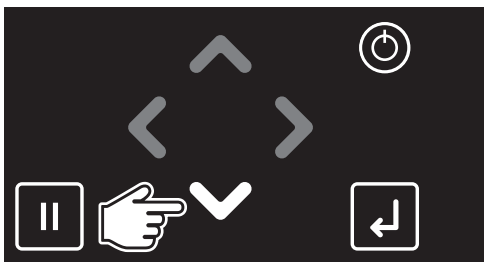

Advance the roll media.

- To forward roll media, tap on the printer's panel.



- To cut the leading edge of the roll media, tap [Cancel] on the printer's panel. **Make sure to cut it if you are loading a new roll media or leading edge of the roll media is not straight.**

Operation manual for each printer

- **If the leading edge is not straight, it will cause media warps or skew, leading to print defects.**

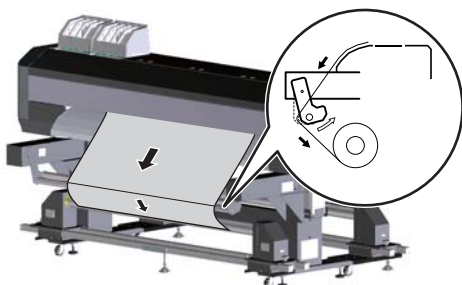

- As shown to the left, feed the roll media until its leading edge passes through the front tension roller and reaches the paper core without warps. In this state, the tension roll is leaning to the printer side.
- Once it reaches the intended position, release .
- To rewind roll media, tap on the printer's panel.

[5]

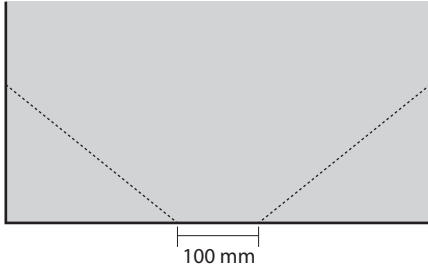
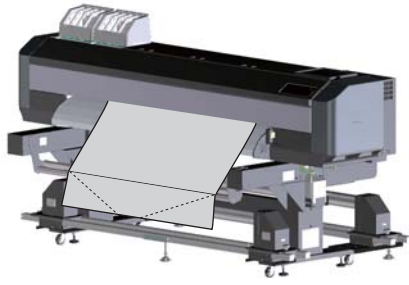

Cut the leading edge of the roll media with the cutter.

- Leave the center on the leading edge of the media about 100 mm and cut diagonally to be symmetrical against the roll media as shown.

Note

- Cut one side first. Place a scrap of the media you cut on the other side to cut symmetrically.

[6]

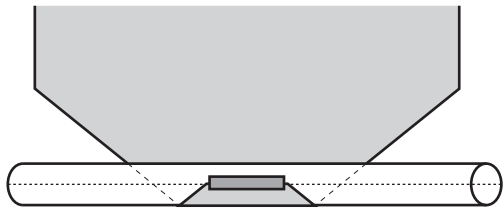
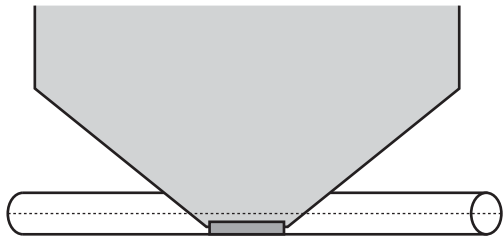
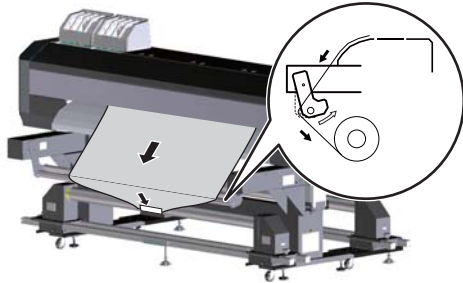

Fix the leading edge of the media using tape so that the tip is parallel to the paper core.

- Hold the leading edge of the roll media with your both hands to check that the tension on the left and right side is equal and pull it straight with equal force. In this state, the tension roll is leaning to the printer side.

To wind with the printed side face out:

- Align the leading edge with the lower part of the paper core without media warps.
- Keep the leading edge parallel to the paper core and tape it.

To wind with the printed side face in:

- Pass the roll media from back to front under the paper core without warps and align the leading edge with the front of the paper core as shown.
- Keep the leading edge parallel to the paper core and tape it.

Note

- In case of Inside roll, you will need to feed roll media longer than the amount fed in the step 4. Use or on the printer's panel to adjust feeding amount.

[7]

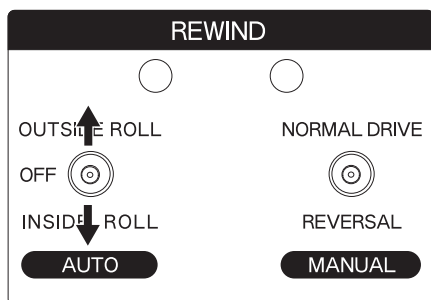

Switch the Take-up Unit AUTO switch depending on the media you are setting.

- INSIDE ROLL: To wind with the printed side face in.
- OUTSIDE ROLL: To wind with the printed side face out.

[8]

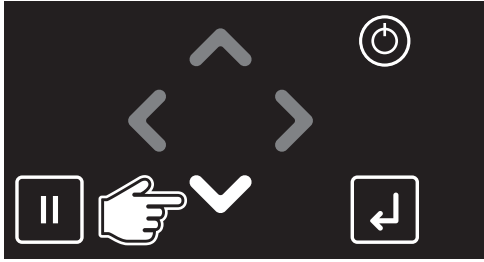

Advance the roll media.

- To forward roll media, tap  on the printer's panel.

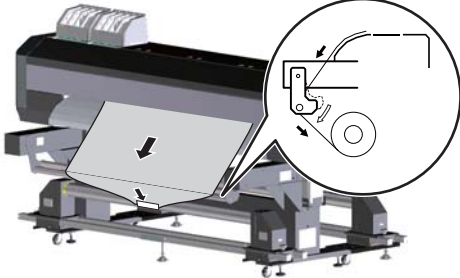

- The take-up unit automatically start winding the roll media.
- Keep tapping  until the take-up unit winds the roll media around the paper core two or three times.

[9]

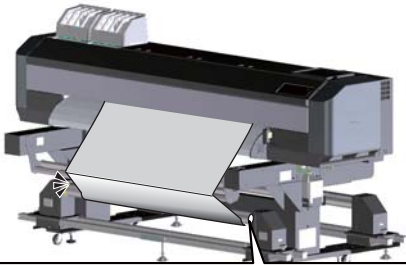

Look at the paper core to see if media skew occurs.

- Check if both ends of the roll media wound around the paper core are aligned. Skew occurs if it is misaligned.
- Check if the tension on the left and right side of the media between the paper core and front tension roller is equal.

 **Note**

- In case skew occurs, go back to the step 6 to tape the edge of the roll media to the paper core again.

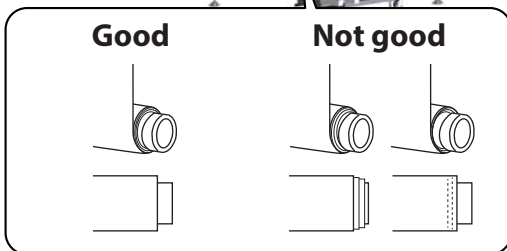

After loading the media...

The printer performs media initialization when a roll media is loaded in the printer. However, the position of the media might be shifted in the later steps. Follow these steps to perform media initialization again with the roll media loaded.

[1]

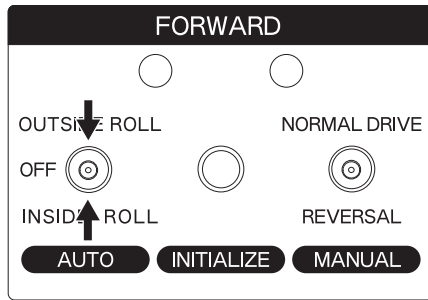

Set the AUTO switch of the Feed Unit to "OFF".

[2]

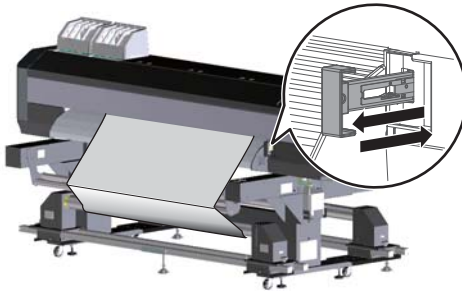

With the roll media loaded in the printer, perform media detection.

- From the front of the printer, hold the front tension roller with your one hand and pull the media feed lever towards you. Then push the lever back to the original position. The printer will automatically start media initialization.

[3]

Move the rear tension roller to "INITIAL" position.

 [「Moving rear tension roller to "INITIAL" position」 P. 29](#)

Basic Operation

Feed roll media when loaded in the printer (AUTO operation)

When a roll media is loaded in the printer and take-up unit correctly, the take-up unit automatically feeds and winds roll media in sync with the printer.

Important!

If you switch from MANUAL to AUTO operation, make sure to press the INITIALIZE button to move the rear tension roller back to "INITIAL" position. If it is not in "INITIAL" position, the internal sensor will not work correctly, failing to perform proper media feeding.

 [「Moving rear tension roller to "INITIAL" position」 P. 29](#)

[1]

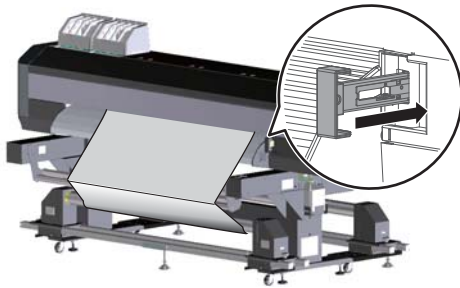

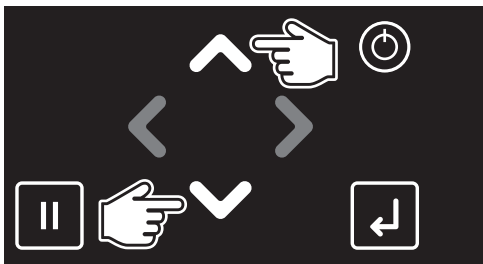

Check that the pressure rollers are locked (lowered).

[2]



Tap  or .

- : The printer feeds roll media wound on the take-up unit back to the feed unit.
- : The printer feeds roll media wound on the feed unit to the take-up unit.

[3] Once it reaches the intended position, release the key.

Wind cut media around paper core (MANUAL operation)

To manually wind the printed media cut from the roll media, follow these steps.

- [1] Use the media cutting function on the printer to cut the media.

 Operation manual for each printer

- [2]

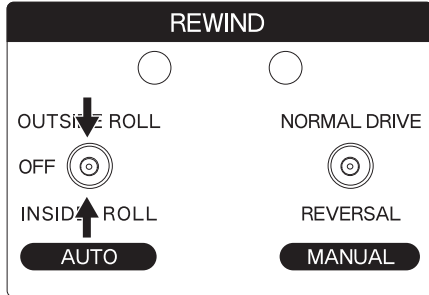

Set the AUTO switch of the Take-up Unit to "OFF".

- [3]

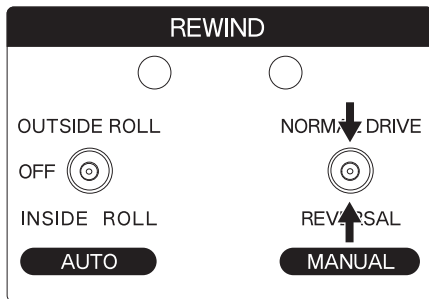

Switch the Take-up Unit AUTO switch depending on the media you are setting.

To wind with the printed side face out:

- "NORMAL DRIVE" will wind roll media

To wind with the printed side face in:

- "REVERSAL" will wind roll media

When the red lamp blinking

- [1]

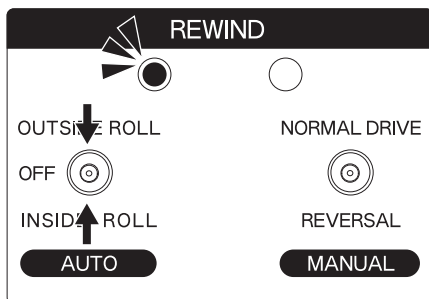

Set the AUTO switch on the side where the red lamp blinking to "OFF".

- [2]

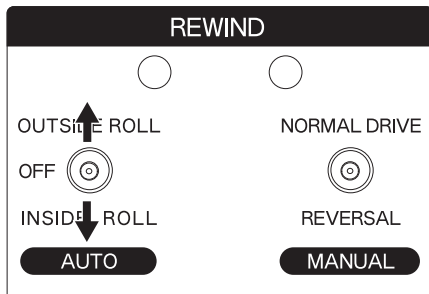

Set the AUTO switch according to the media rolling direction.

Moving rear tension roller to "INITIAL" position

With roll media loaded on the take-up unit, if you turn on/off this unit or feed roll media by MANUAL operation, follow these steps to move the rear tension roller to "INITIAL" position.

[1]

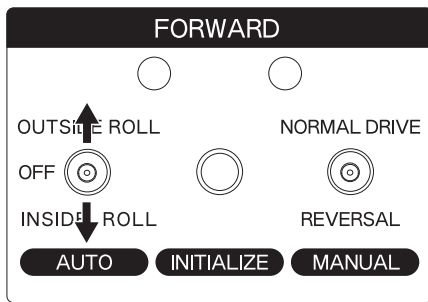

Switch the Feed Unit AUTO switch depending on the media you are setting.

- INSIDE ROLL: When setting the inside roll media.
- OUTSIDE ROLL: When setting the outside roll media.

Note

- Inside roll media: Media with the printable side on the inside.
- Outside roll media: Media with the printable side on the outside.

[2]

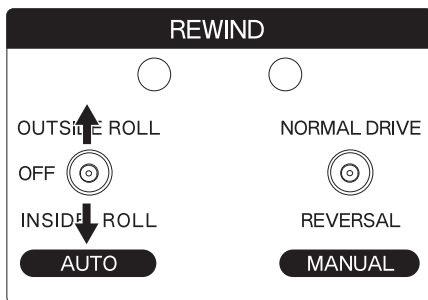

Switch the Take-up Unit AUTO switch depending on the media you are setting.

- INSIDE ROLL: To wind with the printed side face in.
- OUTSIDE ROLL: To wind with the printed side face out.

[3]

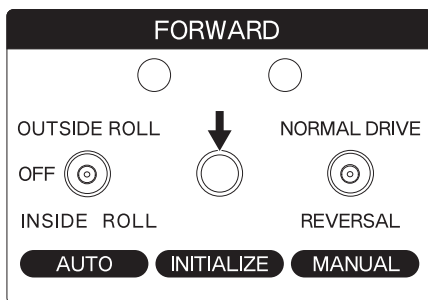

Press INITIALIZE button.

- Move the rear tension roller to "INITIAL" position.

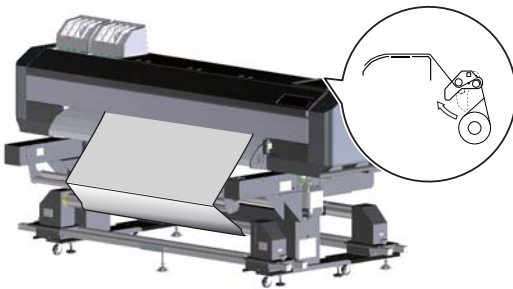

Note

- If it is not in "INITIAL" position, the internal sensor will not work correctly, failing to perform proper media feeding.

Maintenance

To maintain the performance of this product, please conduct maintenance by yourself.

Cleaning the Take-up Unit

Cleaning period:

- When ink stains are visible

Preparation:

If you are using eco-solvent ink:

- Paper towel or Soft cloth
- Ethanol (commercially available item: Use one with a concentration of 50% or higher.)

If you are using sublimation transfer ink:

- Soft cloth

CAUTION



Unplug the power cable with the power OFF, before cleaning the Take-up Unit.

Steps

- [1] Unload the media.
- [2] Make sure that the printer and the Take-up Unit are turned OFF.

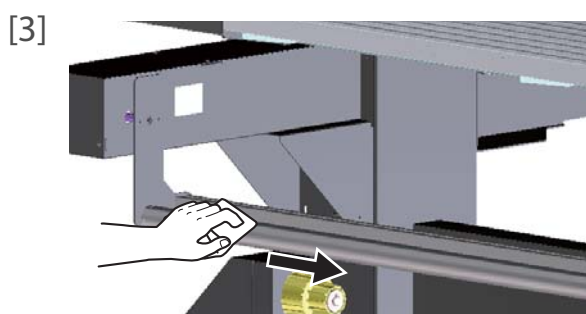

If you are using eco-solvent ink:

- Use a soft cloth or paper towel slightly dampened with ethanol to clean the tension rollers of the Take-up Unit.

If you are using sublimation transfer ink:

- Use a wet, tightly-wrung soft cloth to clean the tension rollers of the Take-up Unit.

Cleaning off paper dust

Cleaning period:

- When loading a roll media

Preparation:

- Soft cloth

CAUTION



Unplug the power cable with the power OFF, before cleaning the Take-up Unit.

Steps

- [1] Unload the media and remove the paper core.
- [2] Make sure that the printer and the Take-up Unit are turned OFF.

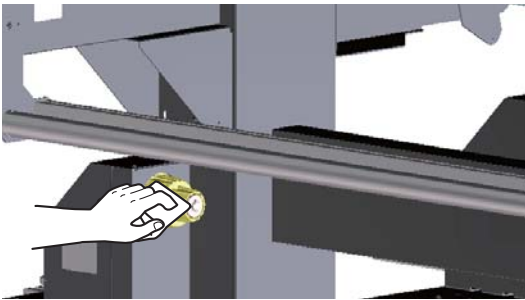
- [3]  Using a soft cloth dampened with water and wrung it out, clean off paper dust from the media flanges on both front and rear rail unit.

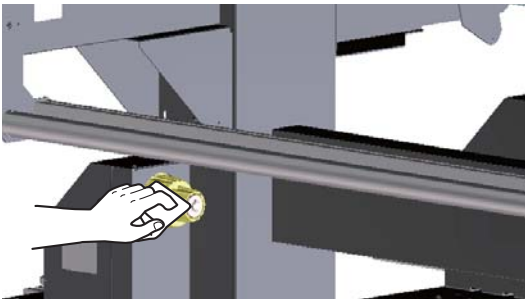

Moving or transporting the printer

This section describes how to move or transport the printer.

Moving the printer

Important!

- If you want to change the installation site of this product, contact your MUTOH dealer you purchased the product from, then remove it from the printer for moving. MUTOH cannot guarantee the performance if you move the printer with this product installed.
If you have no choice but to move the printer without removing this product, avoid slope or rough road and move it for short distance up to 100 m.
- When moving the printer, make sure to maintain a horizontal position.
- Do not tilt, set against something or place this product upside down.
Otherwise the ink may leak or the handling mentioned above may cause abnormality.

1. Preparation before moving

[1] Unload the media and remove the paper core.

[2]

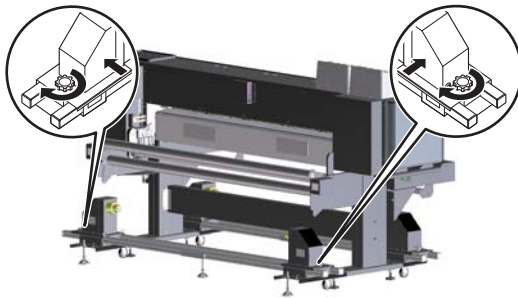

Tighten the handle of the front and rear roll unit.

[3] Make sure that the printer and take-up unit are turned OFF.

[4] Remove all the cables, such as Power cord set.

[5] Remove all the cables, such as Power cord set.

[6]

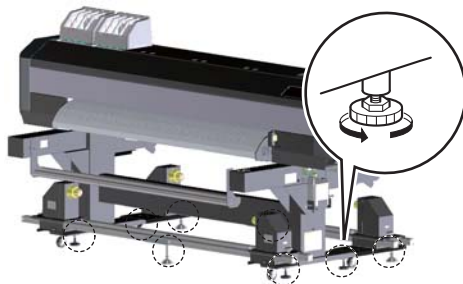

Rotate all the leveling adjusters on the stand (x4) and take-up unit (x4) anticlockwise to raise them.

Note

- Raise the adjusters to the top to avoid reaching the floor when moving.

[7]



Secure the front tension roller with tape for moving.

- Tape the balance frame on the front tension roller and front rail unit with one tape.

Important!

- **Do not tape on the rollers. If deformed, it may not be able to feed media properly.**

[8]

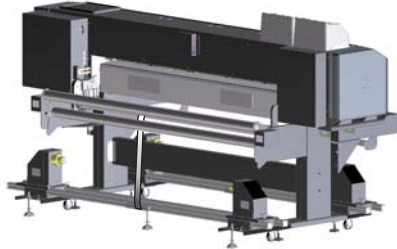

Secure the rear tension roller with tape for moving.

- Tape the balance frame on the rear tension roller and rear rail unit with one tape.

Important!

- **Do not tape on the rollers. If deformed, it may not be able to feed media properly.**

[9] Move the printer.

2. Reinstalling

[1] Select a suitable place for installation.

Startup Guide for each printer

INSTALLATION MANUAL

[2] Move and install the printer to the location.

[3] Attach Cables, such as Power cord set.

[4] Perform Nozzle check, and then confirm that there is no clogging in Print head.

Operation manual for each printer

[5] Perform print quality adjustment.









Operation manual for each printer











Transporting the printer

When transporting the printer, make sure to pack it in the same condition as purchased, using protective and packing materials to protect the printer from vibration and shocks.

Important!

When transporting the printer, consult the MUTOH product dealer at your point of purchase.

Symptom	Possible cause and Remedy
<p>The Take-up Unit does not work.</p>	<p>Is the power cable connected to the plug?</p> <ul style="list-style-type: none"> Connect the power cable.  1 Connecting the cables
	<p>Is the AUTO switch of Take-up Unit set to either OUTSIDE ROLL or INSIDE ROLL?</p> <ul style="list-style-type: none"> Flip the AUTO switch according to the printing side of a roll media, then press the INITIALISE switch.  Moving rear tension roller to "INITIAL" position
	<p>Did you press the INITIALISE switch after turning on the take-up unit?</p> <ul style="list-style-type: none"> Flip the AUTO switch according to the printing side of a roll media, then press the INITIALISE switch.  Moving rear tension roller to "INITIAL" position
	<p>Did you remove/insert the power cord after turning on the take-up unit?</p> <ul style="list-style-type: none"> Flip the AUTO switch according to the printing side of a roll media, then press the INITIALISE switch.  Moving rear tension roller to "INITIAL" position
	<p>Is the error lamp on the take-up unit light up?</p> <ul style="list-style-type: none"> Set the AUTO switch on the side where the red lamp has lit up to "OFF". Set the AUTO switch according to the media rolling direction.  When the red lamp blinking
	<p>Is the error lamp on the take-up unit blinking?</p> <ul style="list-style-type: none"> Overcurrent error occurs. Turn off the take-up unit and remove the cause of the error, then reboot the take-up unit.  Turning the power OFF  Turning the power ON
	<p>Did you turn the AUTO switch on the take-up unit according to the printing side of the roll media before turning the MANUAL switch?</p> <ul style="list-style-type: none"> Press INITIALIZE button.  Moving rear tension roller to "INITIAL" position

Symptom	Possible cause and Remedy
<p>Take-up Unit does not correctly feed or windroll media.</p>	<p>Is the AUTO switch of Take-up Unit set to either OUTSIDE ROLL or INSIDE ROLL?</p> <ul style="list-style-type: none"> Flip the AUTO switch according to the printing side of a roll media, then press the INITIALISE switch.  Moving rear tension roller to "INITIAL" position <hr/> <p>Did you press the INITIALISE switch after turning on the take-up unit?</p> <ul style="list-style-type: none"> Flip the AUTO switch according to the printing side of a roll media, then press the INITIALISE switch.  Moving rear tension roller to "INITIAL" position <hr/> <p>Did you remove/insert the power cord after turning on the take-up unit?</p> <ul style="list-style-type: none"> Flip the AUTO switch according to the printing side of a roll media, then press the INITIALISE switch.  Moving rear tension roller to "INITIAL" position <hr/> <p>Is the media loaded correctly?</p> <ul style="list-style-type: none"> Load the media correctly.  Set the media to the Feed Unit  Put the media through the printer from the Feed Unit  Remove any warps or skew from the roll media on the Feed Unit  Attaching roll media to the paper core <hr/> <p>Are the front rail and rear rail on the take-up unit parallel to the printer?</p> <ul style="list-style-type: none"> Before loading a roll media, the length of media path should be adjusted so that the rail unit is parallel to the printer. Only trained service personnel can perform this adjustment.
<p>The printed media is wound on the Take-up Unit with wrinkles.</p>	<p>Is the media loaded correctly?</p> <ul style="list-style-type: none"> Load the media correctly.  Set the media to the Feed Unit  Put the media through the printer from the Feed Unit  Remove any warps or skew from the roll media on the Feed Unit  Attaching roll media to the paper core <hr/> <p>Are the front rail and rear rail on the take-up unit parallel to the printer?</p> <ul style="list-style-type: none"> Before loading a roll media, the length of media path should be adjusted so that the rail unit is parallel to the printer. Only trained service personnel can perform this adjustment.

Safety Instructions

Important Notice

For Users in Europe



The CE marking is a mandatory European marking for certain product groups to indicate conformity with the essential health and safety requirements set out in European Directives.

By affixing the CE marking, the manufacturer, his authorized representative, or the person placing the product on the market or putting it into service ensures that the item meets all the essential requirements of all applicable EU directives and that the applicable conformity assessment procedures have been applied.



For Users in the United States

This equipment has been tested and found to comply with the limits for a Class A digital device, pursuant to Part 15 of the FCC Rules. These limits are designed to provide reasonable protection against harmful interference when the equipment is operated in a commercial environment. This equipment generates, uses, and can radiate radio frequency energy and, if not installed and used in accordance with the instruction manual, may cause harmful interference to radio communications.



Operation of this equipment in a residential area is likely to cause harmful interference in which case the user will be required to correct the interference at his own expense.

About the safety notices

Signification of WARNING and CAUTION

 WARNING	Used for dangerous situations where death or serious injury may be caused.
 CAUTION	Used for dangerous situations that may cause slight or medium injury, or when all or parts of products are damaged.

Meaning of symbols

Warning symbol	Meaning
	Indicates "prohibited" operations.
	Indicates "required" operations.

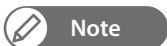

Note

Refer to "Introduction" of the operation manual for names of each component in the main body.

Concerning electric shock, short circuits and fire

WARNING



Do not install the printer where it is humid or dusty.
It could lead to an electric shock and fire.



Do not use a damaged power cable.
It could lead to an electric shock and fire.



Do not pull out or insert the power plug with a wet hand.
This could lead to an electric shock.



Do not connect an earth wire to the following places.

- Gas pipe
There is a possibility of ignition and explosion.
- Earth wire of telephone cables and lightning rods
Heavy current might flow whenever lightning strikes.
- Water pipe and faucet
The earth might not work if a plastic pipe is connected in the middle of the metal pipe.



Do not insert or drop metal or flammable objects into the printer through openings such as a vent.
It could lead to an electric shock or fire.



If foreign substances or liquids such as water entered the printer, do not use the printer as it is.
It could lead to an electric shock or fire.
Turn the power button OFF immediately and disconnect the power plug from outlet. Then contact the customer support.



Do not block the vent on the product with cloth or other material.
If you cover the vent, the product interior may get hot and cause a fire.



Pay attention to the following points when handling the power cord set.

- Do not tamper with the power cord set.
- Do not put heavy objects on the power cord set.
- Do not bend, twist or pull the power cord set by force.
- Do not route the power cord set near heating appliances.



Pay attention to the following points when handling the power plug.
Any mishandling of the power cable could cause a fire.

- Make sure that no foreign substances such as dust are stuck to the power plug.
- Make sure that the power plug is firmly inserted to the edge of the power socket.



Make sure to use only the specified power supply.
If a power supply other than the specified voltage is used, it could cause an electric shock and fire.



Take power for the printer directly from the power socket.
Do not use multiple plugs on the same socket.
This could generate heat and might cause fire.



Be sure to use a dedicated power socket with earth wire for the power supply, and connect it to the earth wire.
If the earth wire is not connected, an electric shock or fire may occur.



Make sure to connect an earth wire to the earth connection that meets the following standards.

- Earth terminal of power socket
- An earth wire with a copper plate which is buried at 650 mm or more in the ground.



Be sure to use the specified power cord set.

- Using a power cord set other than the specified can cause an electric shock or fire.
- Use a power cable that is equipped with a protective grounding terminal, and connect it firmly to the outlet.
- Use a power cable that conforms to the safety regulations, power supply voltage and plug shape of the country where you are using it.



Connect up the cords (cables) in the ways specified in this Guide.
Mistakes in the cable connections could result in fire.



Never open covers attached using screws under any circumstances.
This may cause an electric shock or a malfunction.



When you do not use the printer for a long period, make sure to pull out the power plug from the power socket for safety.



Make sure that no moisture enters the printer.
It could cause shorting of the electrical circuits.

Installing the Take-Up Unit

WARNING



Do not install the printer on a surface:
On such surfaces the printer could topple over or fall off,
potentially causing injury.

- that is shaky, or
- that is tilted, or
- that receives vibration from other machines or equipment nearby.

CAUTION



The operations of unpacking and moving this product must be carried out by two or more persons working together.



Keep this product level when moving it.



This equipment is not suitable for use in locations where children are likely to be present.

Concerning handling

WARNING



Do not step on this printer or place heavy things on top of it.

It may cause an injury if the printer falls down.

CAUTION



Do not use volatile solvents such as thinner, benzene, or alcohol.

These solvents may cause damage to the paint.

When Storing Take-Up Unit

WARNING



Do NOT place this Unit

- **on the area where is not stable or not level**
- **on the floor with busy area**
- **on the tall shelf**

On such places, the Unit could fall off or people can trip over.

CAUTION



When storing this Unit,

- **keep out direct sunlight**
- **avoid high temperature, high humidity and high dust**
- **avoid vibration from other devices.**

If not, it causes damage to the Unit, leading to malfunction.

Warning labels

Warning labels are applied onto the product where special attention is required. Read the messages on the labels and always follows the instructions.

If the labels are peeled off or become dirty, contact the sales store for exchange.

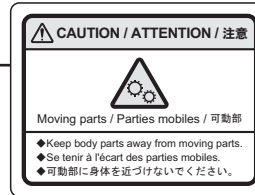
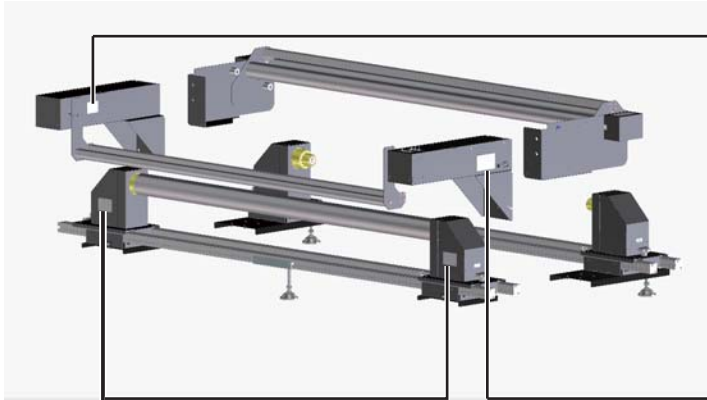

Moving parts Caution Label

Keep body parts away from moving parts.



Crush Hazard Label

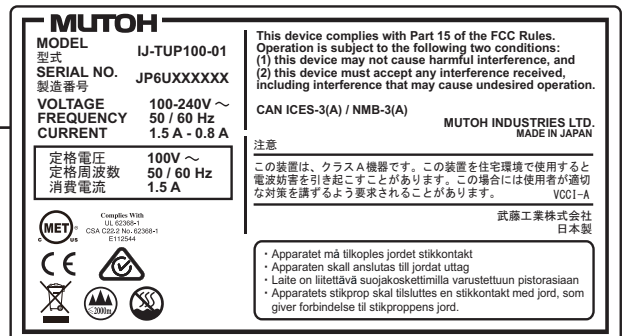

Rating plate

"~" on the rating plate represents AC voltage.

The following warning symbols are requirements in China for "low altitude use" and "non-tropical location".

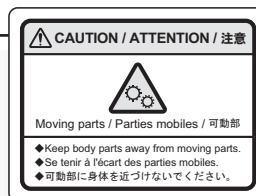
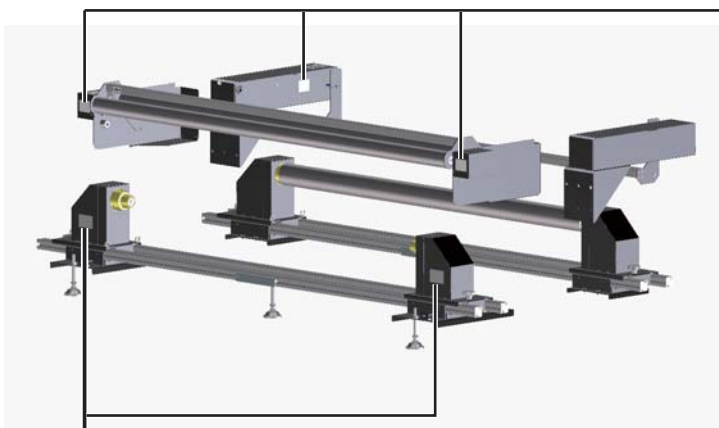

Moving parts Caution Label

Keep body parts away from moving parts.

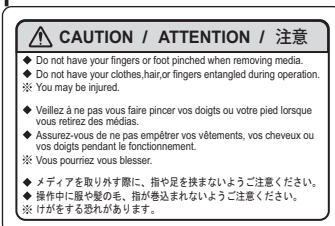

Crush Hazard Label

Instruction labels

Operation instruction labels are applied on the printer at places where caution in operation is required. The contents of these labels are as shown below.

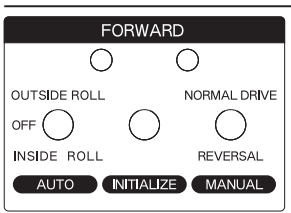

Feed control Label

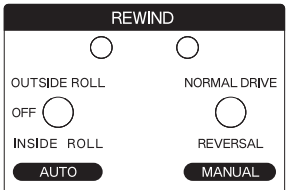

Take-up control Label

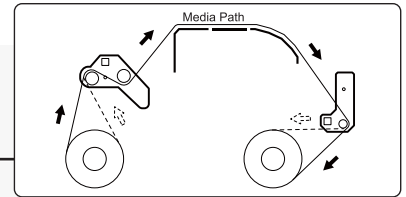

Media Path Label



Rear Label



Front Label

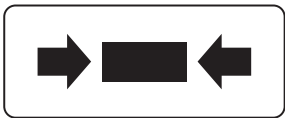

Media registration guide Label



Specifications of this product

Model Name	IJ-TUP100-01	
Drive method	DC Geared Motor Drive	
Conditions of usable media	Maximum width	1,625 mm
	Minimum width	500 mm
	Outside diameter of the roll media	Less than $\Phi 250$ mm
	Media Core Dimension	50.8 mm (2 inch), 76.2 mm (3 inch)
	Supported Media Core Width	1,695 mm
	Roll media weight	100 kg or less
Feeding/ Winding Direction	Outside roll, Inside roll	
Power supply specifications	Voltage	AC 100V to 240V $\pm 10\%$
	Frequency	50/ 60Hz ± 1 Hz
Power consumption	Power off	1.0 W or below
	Standby	20.0 W or below
	Operation	140.0 W or below
Current consumption	100V to 240V	1.5 A or below
Environmental conditions	Operation Environment	Temperature: 20 to 32 °C, humidity: 40 to 60% No condensation
	Recommended Environment	Temperature: 22 to 30 °C, humidity: 40 to 60% No condensation
	Environment for storage	Temperature: -20 to 60 °C, humidity: 40 to 80% No condensation
External dimensions	Height	798 mm
	Width	2,373 mm
	Depth	1,584 mm
Weight	When attaching the weights to the front side.	85 kg
	When attaching the weights to the rear side.	84 kg

Note

- The “Dimensions” describes the maximum size that the take-up unit is attached to the stand, including the weights attached to the tension roller (feed/take-up).

Options list

For more information about the options and the supply items, contact your local MUTOH dealer.

Revision History

Date	Version	Manual code
2020.7	00	IJ-TUP100-01E-A-00
2024.7	01	IJ-TUP100-01E-A-01

MUTOH